



**MANUAL DE MONTAGEM  
ASSEMBLY INSTRUCTIONS  
INSTRUCCIONES DE MONTAJE**

**COD BR: BE 73**



# Sumário Summary Resumen

Introdução Introduction Introducción	.....	3
Antes de começar Before starting Antes de comenzar	.....	4
Evite acidentes Avoid accidents Evitar accidentes	.....	4
Dimensões e ferramentas Dimensions and tools Dimensiones y herramientas	.....	5
Identificação das peças Identifying parts Identificación de las piezas	.....	6
Acessórios incluídos na caixa Hardware included in box Accesorios incluidos en la caja	.....	7
Montagem do móvel Furniture assembly Montaje del mueble	.....	8

## Introdução Introduction Introducción

Leia atentamente este manual e siga os passos indicados para que o produto não perca a garantia e também para uma perfeita montagem.

Read this manual and follow the steps in order to keep the guarantee and also for the perfect fit.

Lea este manual y siga los pasos para que el producto no pierda la garantía y también para el ajuste perfecto.

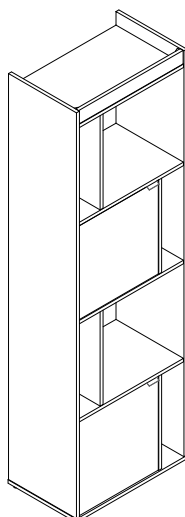

## Antes de começar Before starting Antes de comenzar

Antes de começar a montagem prepare o ambiente, deixando-o completamente limpo e com bom espaço para iniciar o trabalho.

Prepare the room before starting the assembly, leaving it completely clean and the area in good condition to start the work.

Antes de comenzar el montaje prepare el ambiente, dejándolo completamente limpio y con espacio para empezar el trabajo.

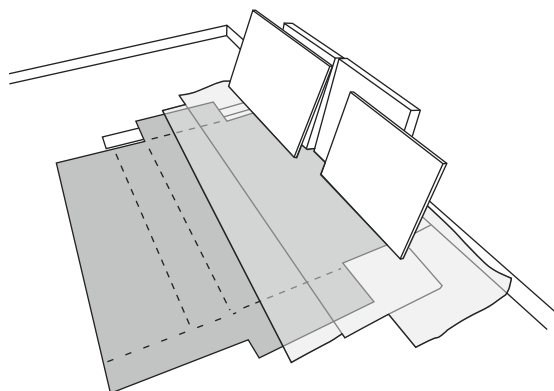

Utilize o papelão da própria embalagem para separar e apoiar as peças retiradas das caixas.

Use the cardboard of the packaging to separate and support the parts removed from the boxes.

Utilice el cartón del embalaje para separar y apoyar las piezas.

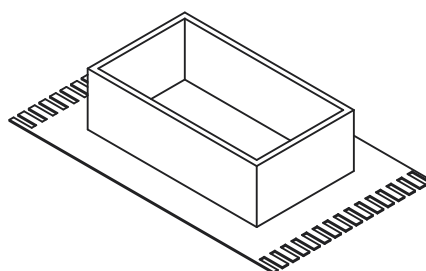

Forre a área de montagem com um cobertor ou tapete. Assim, você evita avarias nas peças durante o processo de montagem.

Cover the assembly area with a blanket or carpet to avoid damaging the parts during the assembly process.

Cubrir la zona de ensamble con una manta o alfombra. De este modo, se evitan daños en las piezas durante el proceso de montaje.



## Evite acidentes Avoid accidents Prevenir accidentes

Solicitamos observar atentamente as orientações de montagem como: fixação do produto na parede, colocação de cola em locais específicos necessários, o peso suportado pelo produto, etc...

You are requested to carefully observe the assembly instructions regarding: fixing of products to the wall, adding glue where indicated, product weight limit, etc.

Pedimos que lea atentamente las instrucciones, principalmente las informaciones de fijación del producto en la pared, colocación de pegamento en local específico y necesario, el peso soportado por el producto etc...

Não escale ou se apoie no móvel.

Do not climb or lean on the furniture.

No se suba ni se apoye en el mueble.

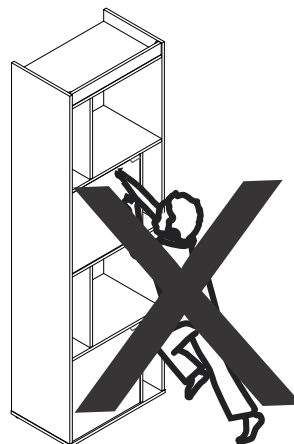

Dimensões e ferramentas  
Dimensions and tools  
Dimensiones y herramientas

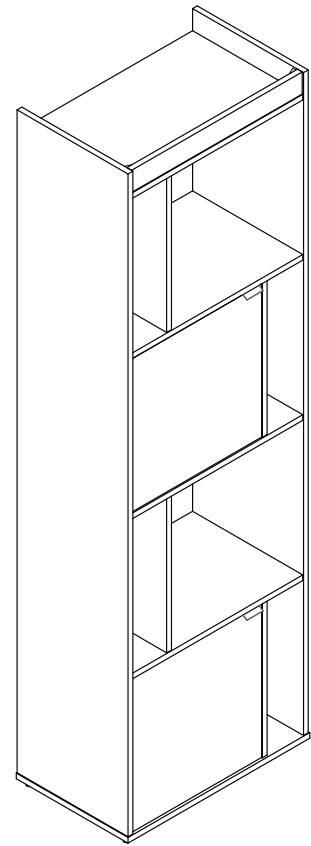

Dimensões:

L: 565 A: 1820 P: 350 mm

Dimensions:

W: 22.24 H: 71.65 D: 13.77 inches

Dimensiones:

L: 565 A: 1820 P: 350mm

Limpeza  
Cleaning  
Limpieza

Pano levemente umedecido com água, seguido de pano seco, não utilizar produtos químicos ou abrasivos.  
You can clean the product with slightly dampened cloth followed by a dry cloth. Do not use chemicals or abrasives.  
Solamente utilizar un paño húmedo y después un paño seco, no utilice productos químicos o abrasivos.

Todas as peças do móvel foram marcadas com um número. Antes de começar a montagem, identifique as peças numeradas em relação às instruções de montagem. Uma vez concluída a montagem, os números podem ser facilmente removidos com um pano ligeiramente embebido em álcool. Use álcool apenas para remover números das peças.

All the furniture parts have been marked with a number. Before you start assembling, please identify the numbered parts in relation to the assembly instructions. Once assembly is completed, the numbers can be easily removed with a cloth slightly dampened in alcohol. Use alcohol only to remove part numbers.

Todos las piezas del mueble fueron marcadas con un número. Antes de empezar el montaje, identifique las piezas numeradas en relación con las instrucciones de montaje. Una vez que se completa el armado, los números se pueden quitar fácilmente con un paño ligeramente empapado en alcohol. Use alcohol solo para eliminar los números de las piezas.

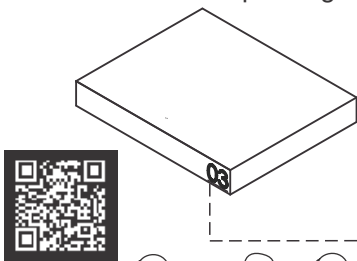

**UTILIZE ALCOOL APENAS PARA REMOVER O NUMERO DAS PEÇAS**  
**USE ALCOHOL ONLY TO REMOVE PART NUMBERS**  
**UTILICE ALCOHOL SOLAMENTE PARA ELIMINAR EL NUMERO DE LAS PIEZAS**

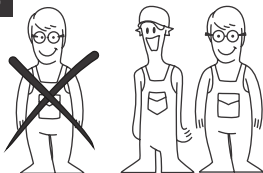

Para facilitar a montagem, utilize uma parafusadeira elétrica.  
To speed assembly, use an electronic screwdriver.  
Para facilitar el armado, utilice un destornillador eléctrico.

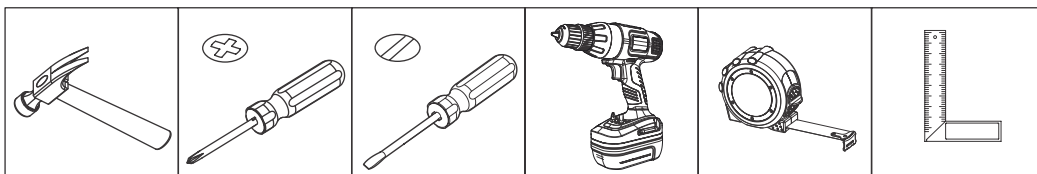

# COD BR: BE 73

PEÇA	DESCRIÇÃO	QUANT.
001	TAMPO	1
002	LATERAL ESQUERDA	1
003	LATERAL DIREITA	1
004	BASE	1
005	PORTA	2
006	PRATELEIRA "A"	2
007	PRATELEIRA "B"	1
008	COSTA	4
009	DIVISÓRIA	4
010	TRAVESSA	1

PART	DESCRIPTION	QTY
001	TOP	1
002	LEFT SIDE	1
003	RIGHT SIDE	1
004	BASE	1
005	DOOR	2
006	SHELF "A"	2
007	SHELF "B"	1
008	BACK	4
009	PARTITION	4
010	TRAVERSE	1

PIEZA	DESCRIPCIÓN	CANTIDAD
001	TAPA	1
002	LATERAL IZQUIERDA	1
003	LATERAL DERECHA	1
004	BASE	1
005	PUERTA	2
006	REPISA "A"	2
007	REPISA "B"	1
008	REVÉS	4
009	PARTICIÓN	4
010	TRAVESAÑO	1

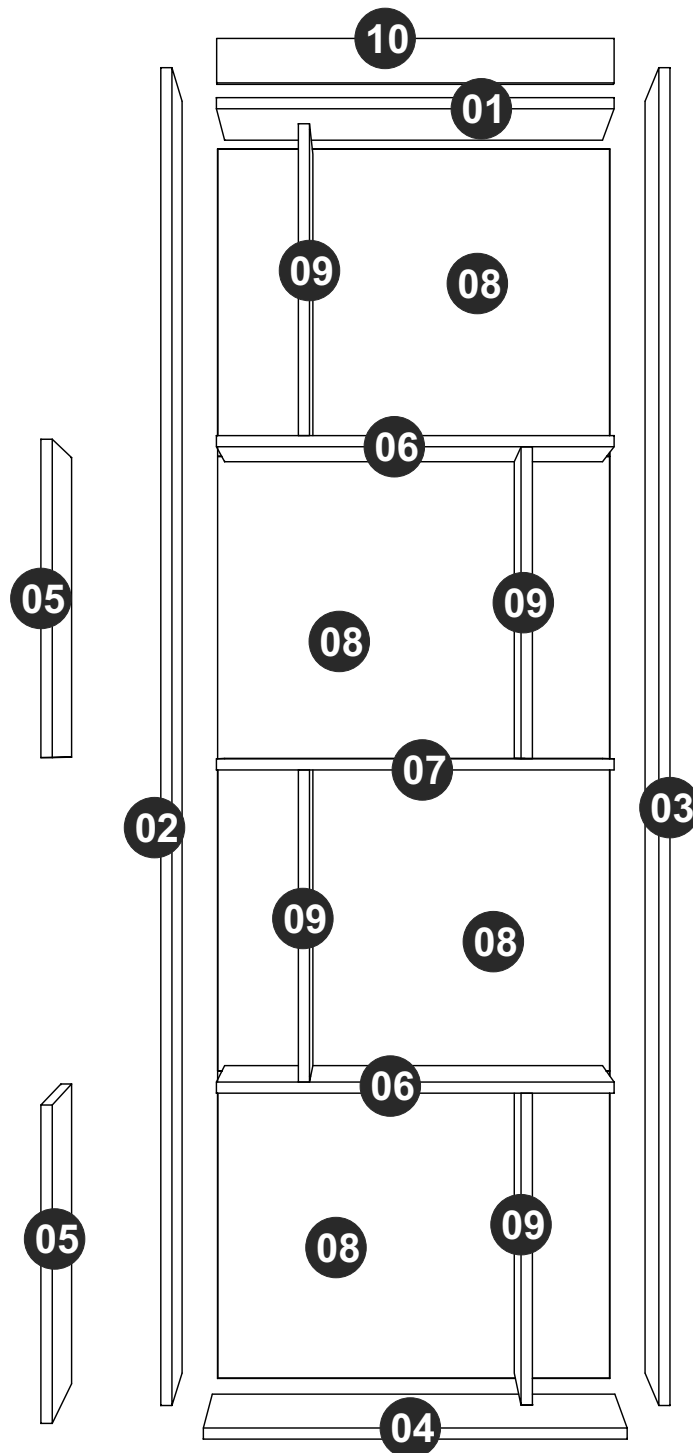

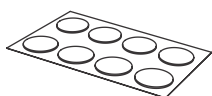

TAPA FUROS x 28  
STICKER x 28  
TAPA HUECOS x 28



EF 000132 x 12  
4x50 CC



EF 000216 X 16



EF 000033 x 36  
8x30

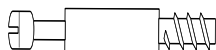

EF 000094 X 16

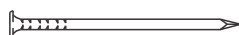

EF 000168 X 76  
10x10 C/C



GIZ x 01  
CHALK x 01  
TIZA x 01



SUPORE PLÁSTICO x 2  
PLASTIC SUPPORT x 2  
SOPORTE PLASTICO x 2

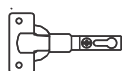

EF 000043 X 4



EF 000025 X 4



EF 000106 x 24  
3,5x14 CC



EF 000107 x 2  
3,5X16 CC

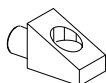

EF 000714 X 2



SUPORE ANGULAR X 2  
ANGULAR SUPPORT X 2  
SOPORTE ANGULAR X 2



PÉS REDONDOS x 4  
ROUND FEET x 4  
PIES REDONDOS x 4

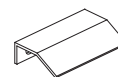

PUXADOR x 2  
HANDLE x 2  
MANIJA x 2

Utilize para medir as ferragens.

Utilice para medir el herraje.

Use for measuring the hardware.

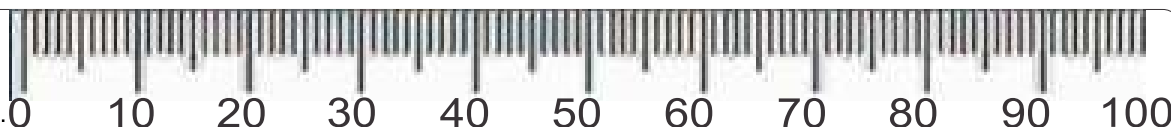

**Garantia (exclusivo para o Brasil/exclusivo de Brasil/exclusive to Brazil):**

A garantia dos produtos fabricados pela BRV Móveis, abrange eventuais defeitos-vícios de fabricação, no prazo estabelecido pelo código de Defesa do Consumidor, em seu artigo 26.II. o qual prevê a garantia de 90 (noventa) dias.

**A** = 5 KG - 11.02 LB

**B** = 2 KG - 4.40 LB

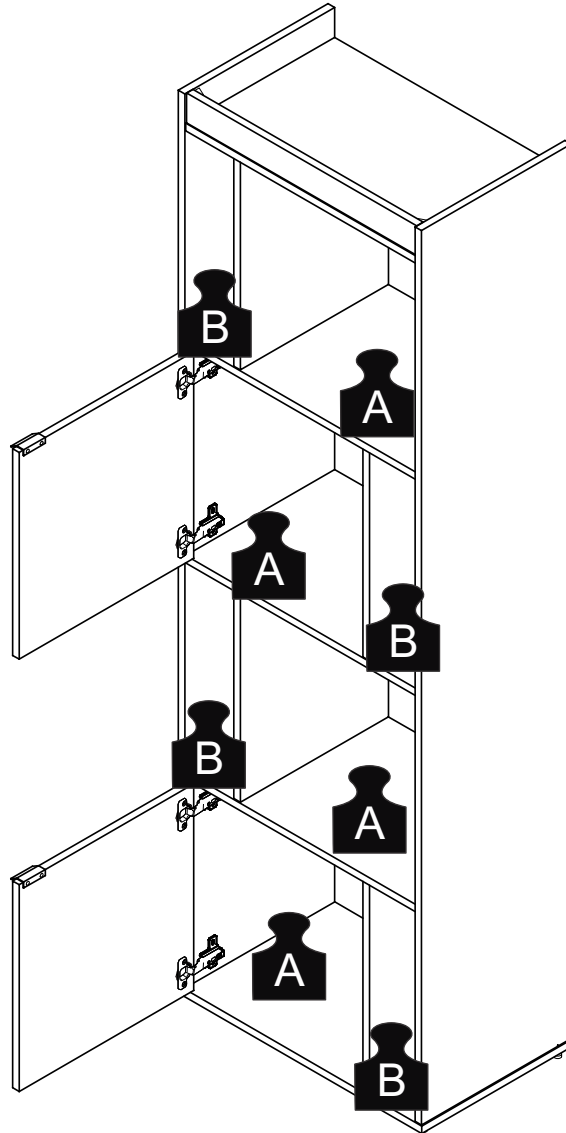

### PASSO 1 / STEP 1 / PASO 1

Fixe a ferragem EF 000094 e EF 000714 nas peças 02 e 03.  
Fixe o suporte angular na peça 10 utilizando a ferragem EF 000106.  
Attach hardware EF 000094 and EF 000714 into pieces 02 and 03.  
Attach the angular support in piece 10 using hardware EF 000106.  
Fije el herraje EF 000094 y EF 000714 en las piezas 02 y 03.  
Fije el soporte angular en la pieza 10 utilizando el herraje EF 000106.

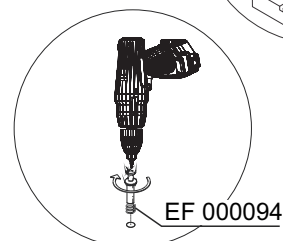
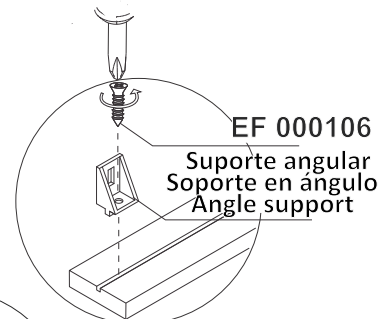
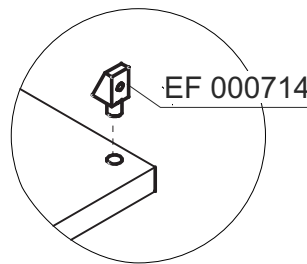
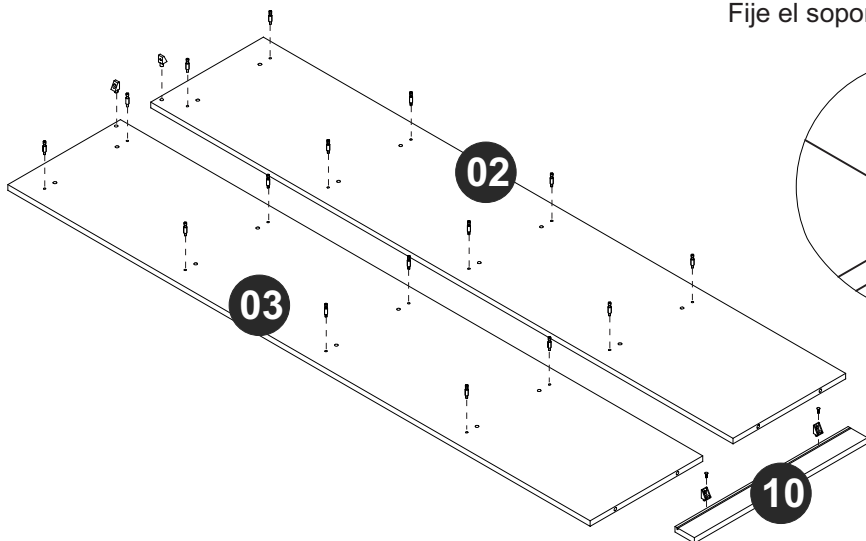



## PASSO 2 / STEP 2 / PASO 2

Insira a ferragem EF 000033 nas peças 02 e 03. Fixe a ferragem EF 000025 na peça 02 utilizando a ferragem EF 000106. Attach hardware EF 000033 in pieces 02 and 03. Attach hardware EF 000025 at piece 02 using hardware EF 000106. Fije el herraje EF 000033 en las piezas 02 y 03. Fije el herraje EF 000025 en la pieza 02 utilizando el herraje EF 000106.

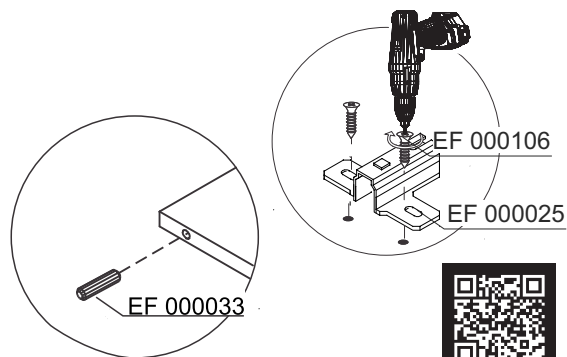
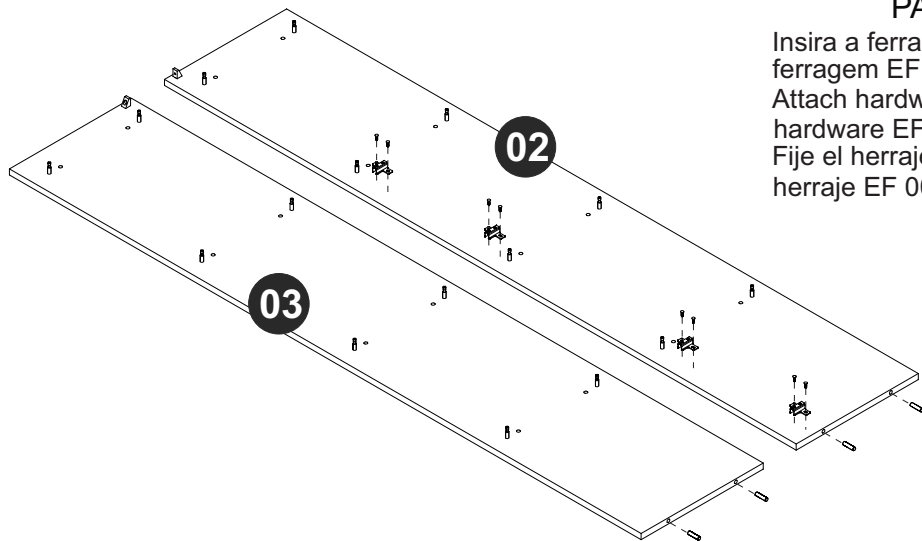

## PASSO 3 / STEP 3 / PASO 3

Insira a ferragem EF 000033 nas peças 01, 06, 07 e 09. Fixe o suporte plástico nas peças 06. Attach hardware EF 000033 in pieces 01, 06, 07 and 09. Attach the plastic support at pieces 06. Fije el herraje EF 000033 en las piezas 01, 06, 07 y 09. Fije el soporte plástico en las piezas 06.

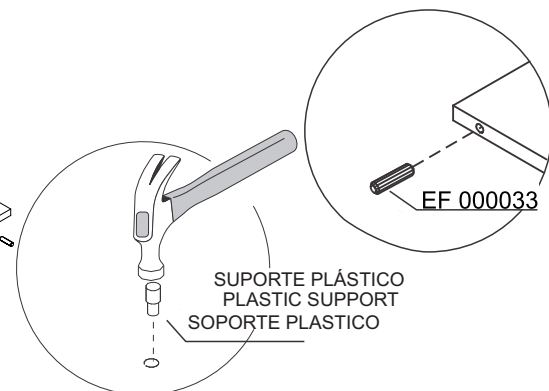
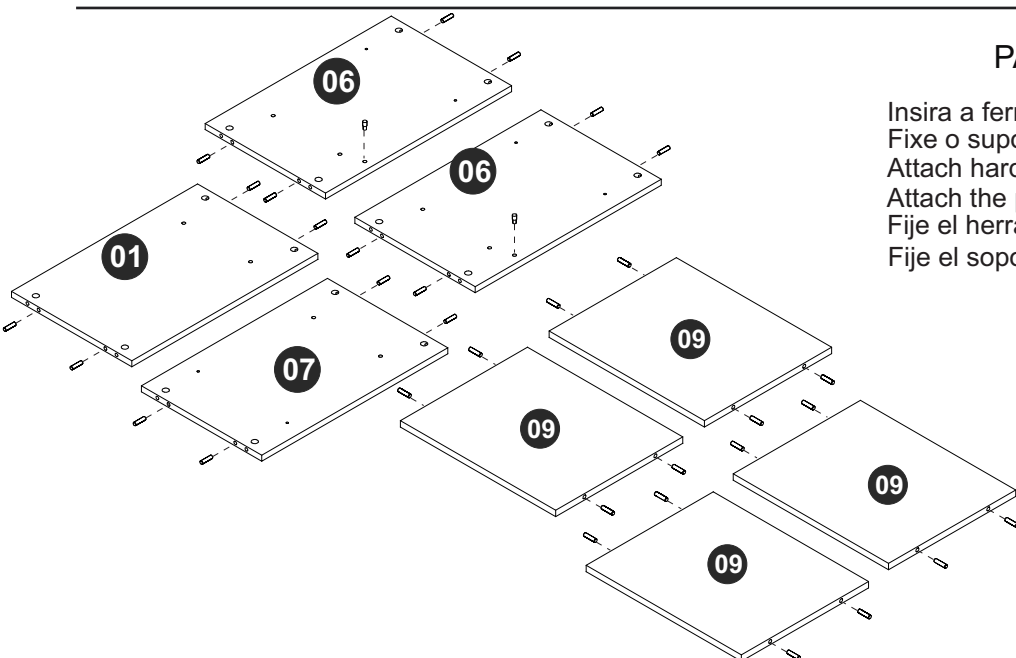

## PASSO 4 / STEP 4 / PASO 4

Fixe o puxador e a ferragem EF 000043 usando a ferragem EF 000106 nas peças 05. Fix the handle and hardware EF 000043 using hardware EF 000106 into pieces 05. Fije la manija y el herraje EF 000043 utilizando el herraje EF 000106 en las piezas 05.

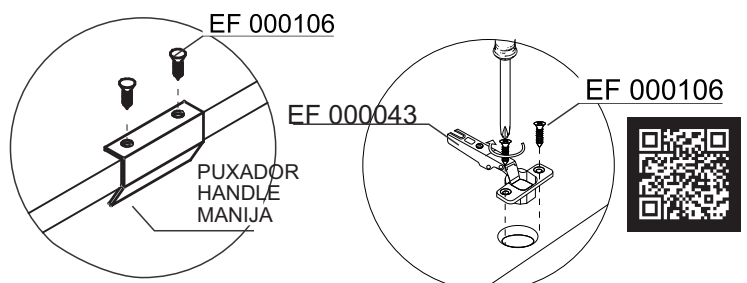
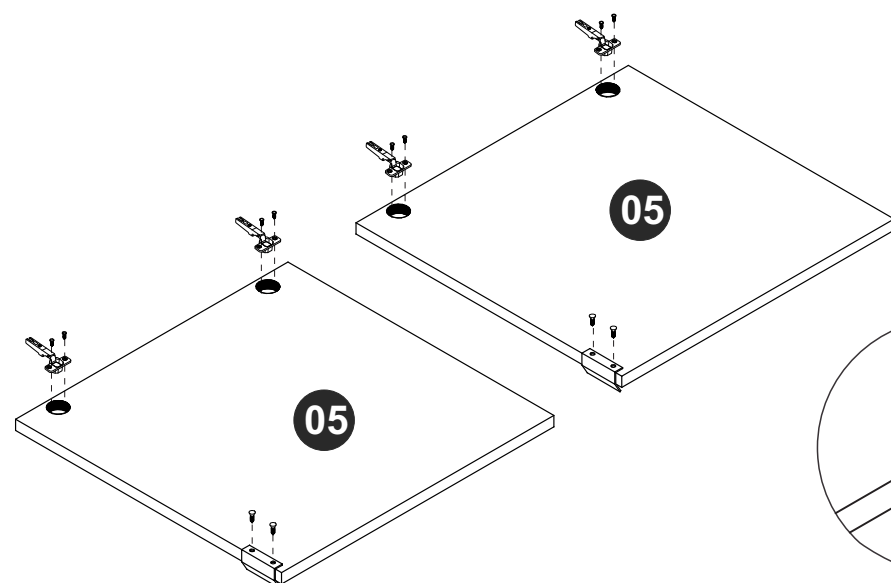

### PASSO 5 / STEP 5 / PASO 5

Conecte as peças 06, 07 e 09 utilizando a ferragem EF 000132.  
Connect pieces 06, 07 and 09 using hardware EF 000132.  
Junte las piezas 06, 07 y 09 utilizando el herraje EF 000132.

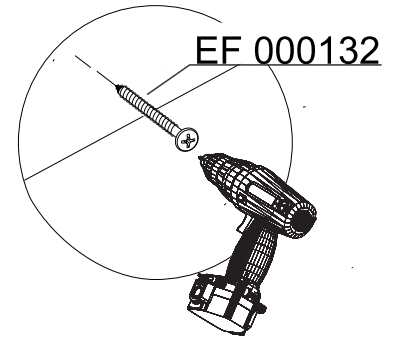
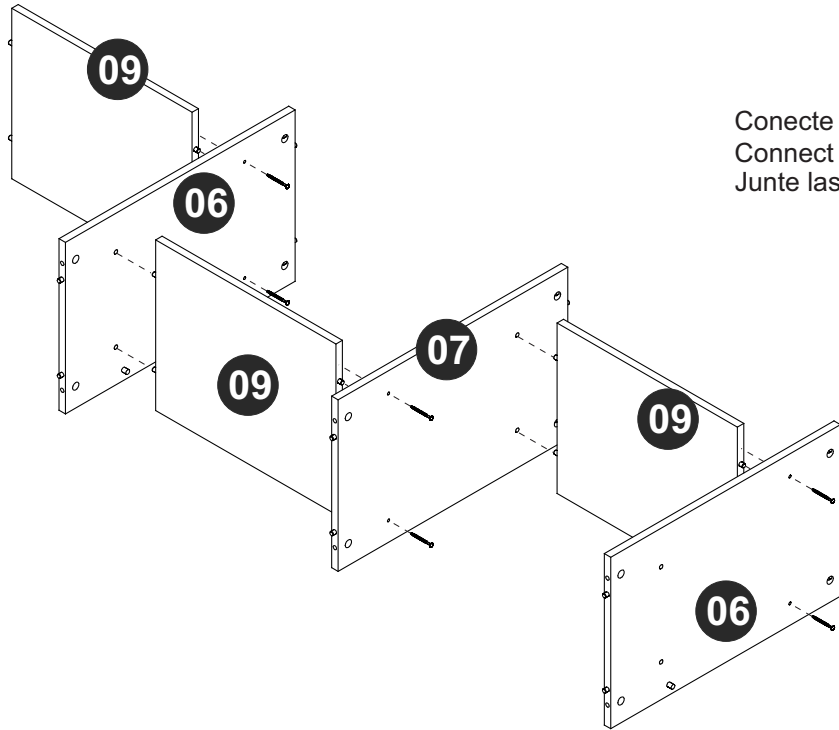

### PASSO 6 / STEP 6 / PASO 6

Conecte as peças 01 e 09 à parte montada no passo anterior.  
Connect pieces 01 and 09 to the part assembled in the previous step.  
Junte las piezas 01 y 09 a la parte armada en el paso anterior.

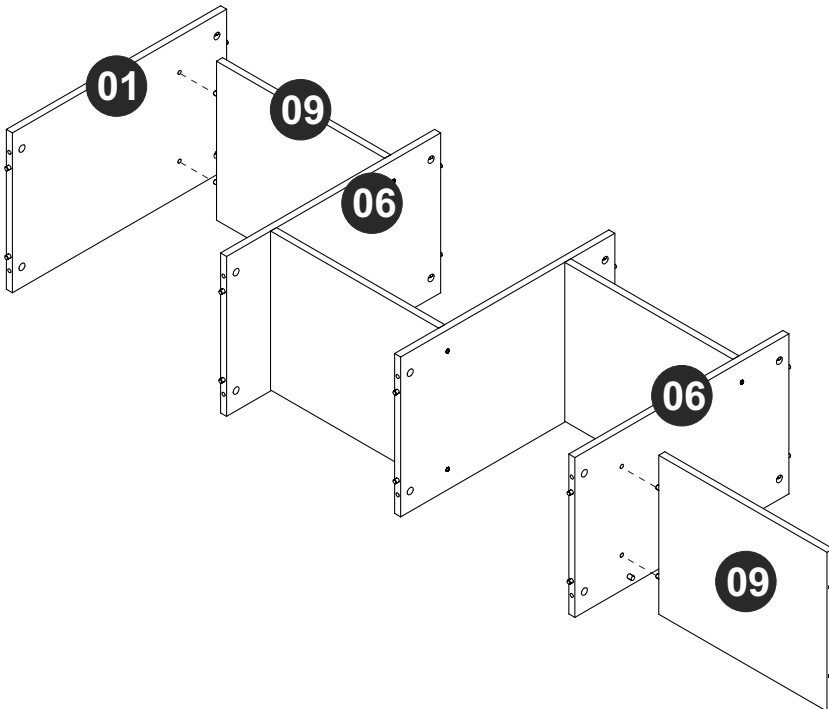

### PASSO 7 / STEP 7 / PASO 7

Conecte a peça 02, insira a ferragem EF 000216 e gire para apertar.  
Connect piece 02, insert hardware EF 000216 and turn to tighten.  
Junte la pieza 02, añáde el herraje EF 000216 y gire para apretar.

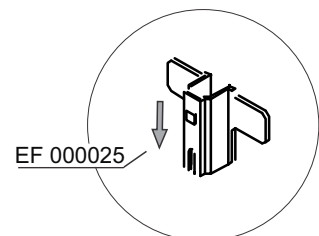
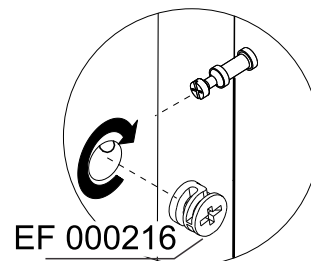
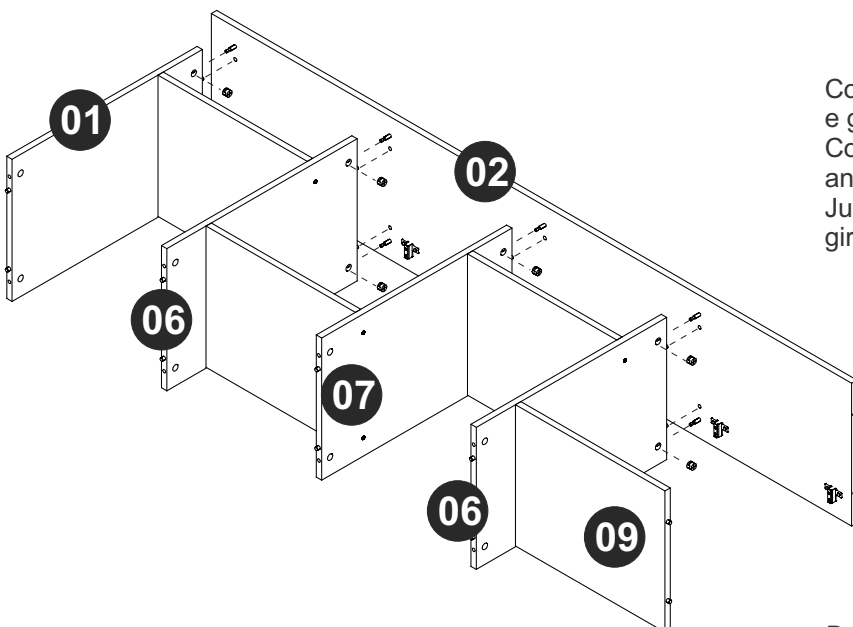

Por favor, observe a posição da ferragem EF 000025.  
Please, note hardware EF 000025 position.  
Por favor, notar la posición del herraje EF000025.

### PASSO 8 / STEP 8 / PASO 8

Conecte a peça 03, insira a ferragem EF 000216 e gire para apertar.  
Connect piece 03, insert hardware EF 000216 and turn to tighten.  
Junte la pieza 03, añáde el herraje EF 000216 y gire para apretar.

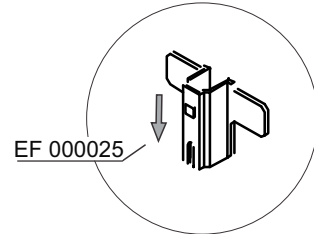
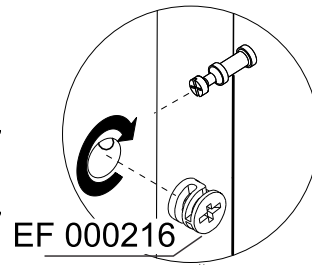
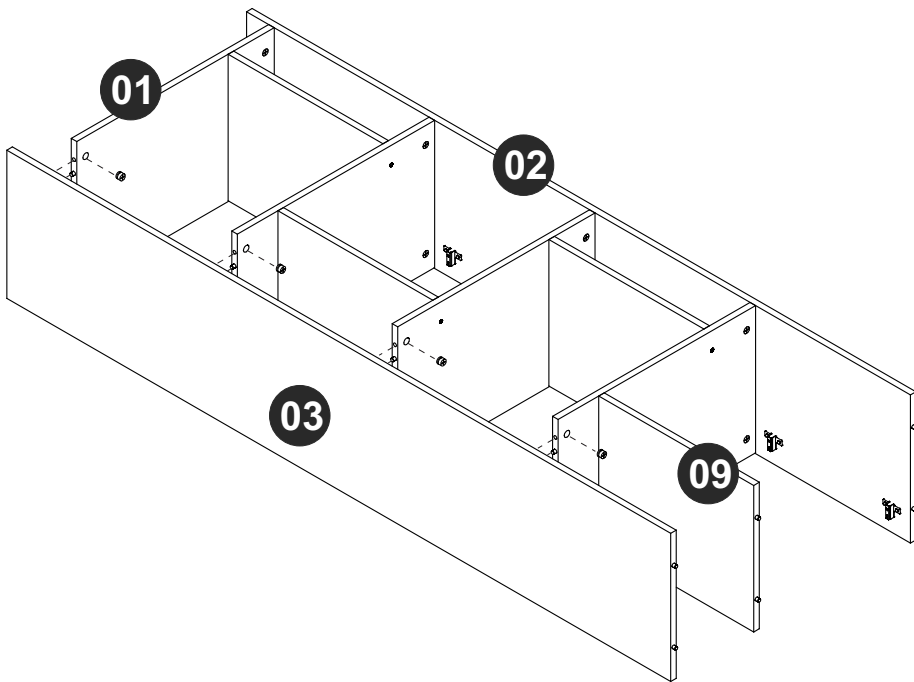

Por favor, observe a posição da ferragem EF 000025.  
Please, note hardware EF 000025 position.  
Por favor, notar la posición del herraje EF000025.

### PASSO 9 / STEP 9 / PASO 9

Fixe a peça 10 utilizando as ferragem EF 000106 e EF 000107.  
Fix piece 10 using hardware EF 000106 and EF 000107.  
Fije la pieza 10 utilizando los herrajes EF 000106 y EF 000107.

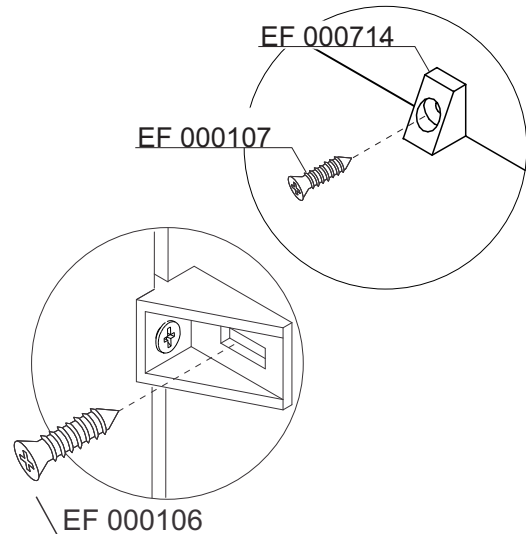
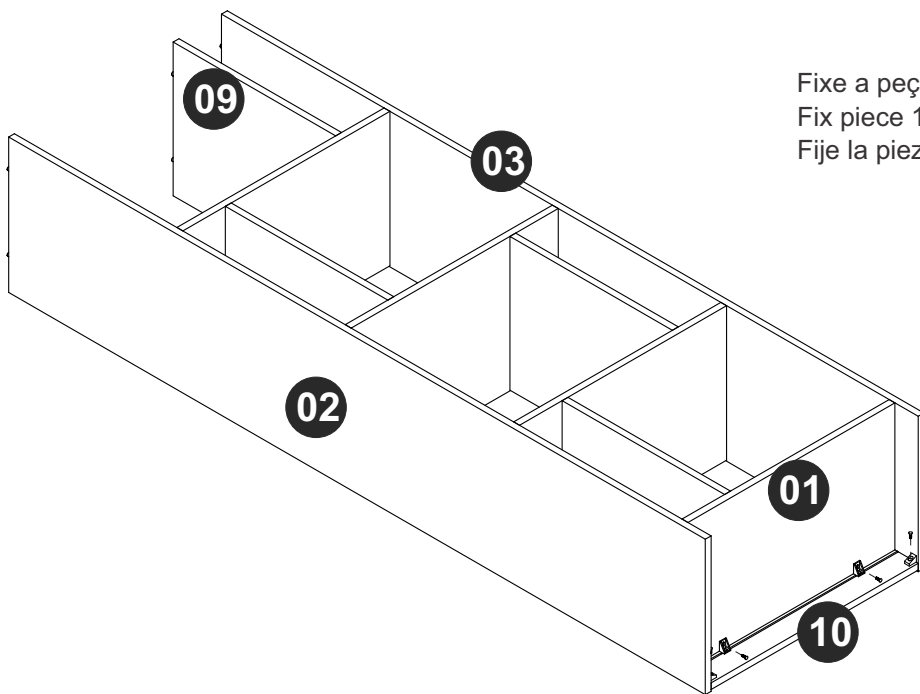

### PASSO 10 / STEP 10 / PASO 10

Fixe a peça 04 utilizando a ferragem EF 000132.  
Fixe os pés na peça 04 utilizando a ferragem EF 000168.  
Fix piece 04 using hardware EF 000132.  
Attach the feet to piece 04 using hardware EF 000168.  
Fije la pieza 04 utilizando el herraje EF 000132.  
Fije los pies a la pieza 04 utilizando el herraje EF 000168.

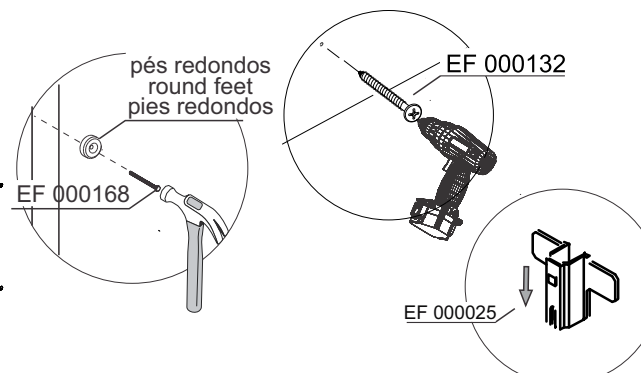
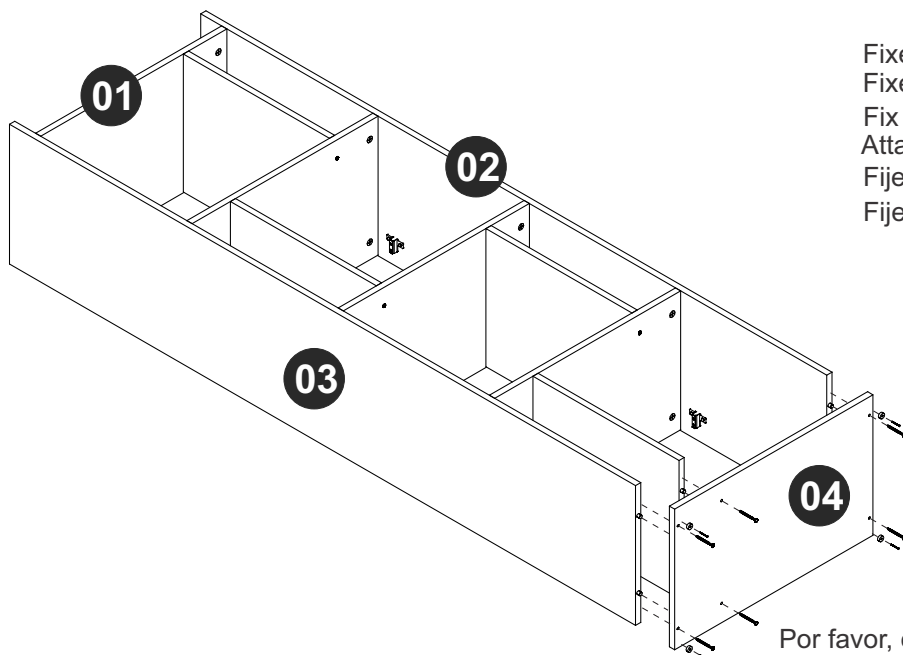

Por favor, observe a posição da ferragem EF 000025.  
Please, note hardware EF 000025 position.  
Por favor, notar la posición del herraje EF000025.

## PASSO 11 / STEP 11/ PASO 11

Fixe as peças 08 ao móvel utilizando a ferragem EF 000168.  
Fix pieces 08 at the furniture using hardware EF 000168.  
Fije las piezas 08 al mueble utilizando el herraje EF 000168.

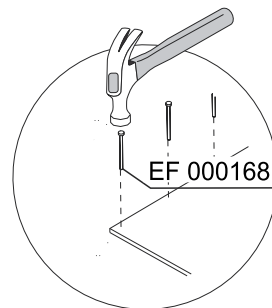
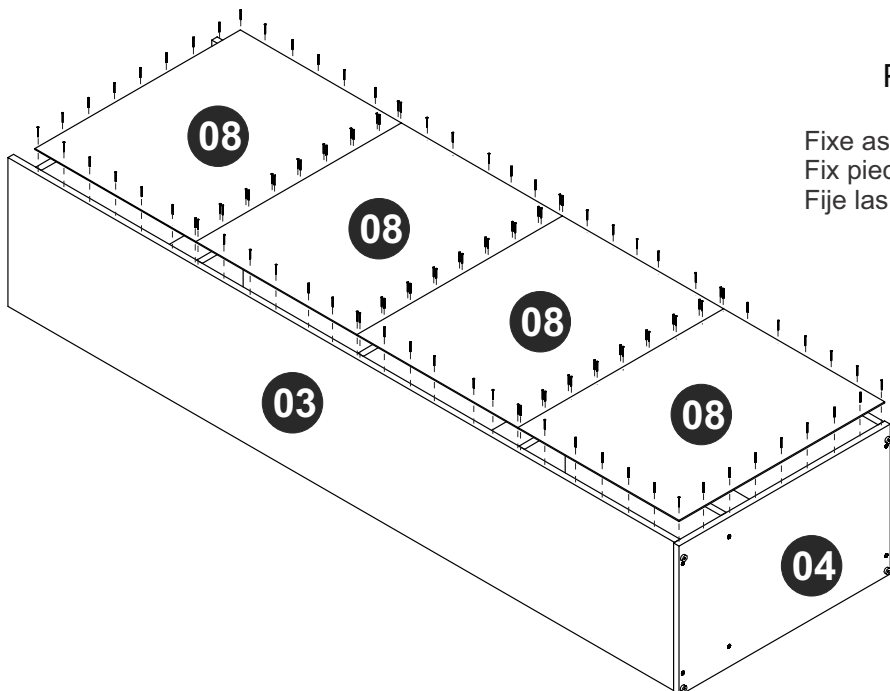

## PASSO 12 / STEP 12 / PASO 12

Fixe as peças 05 ao móvel montado.  
Fix pieces 05 at the assembled furniture.  
Fije las piezas 05 al mueble armado.

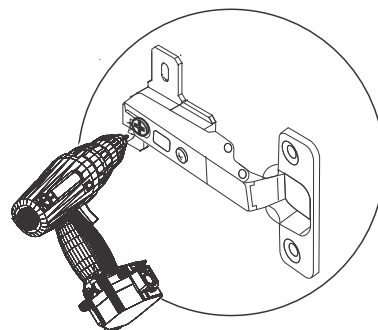
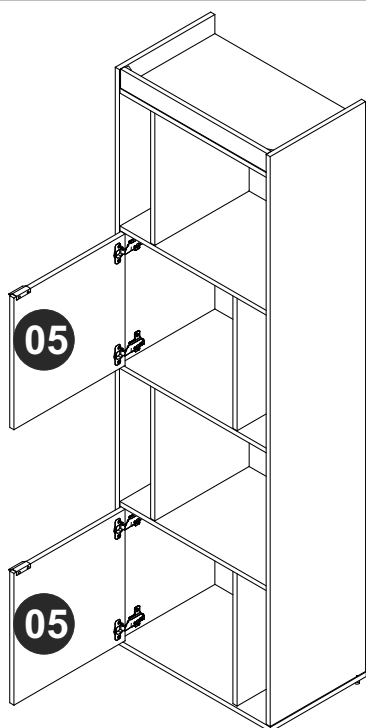

## PASSO 13 / STEP 13 / PASO 13

Use o giz para dar o acabamento final ao produto.  
Use the chalk to give the final finish on the product.  
Utilice la tiza para dar el acabado final al producto.

Use os tapa furos para cobrir os parafusos aparentes.  
Use stickers to cover apparent screws.  
Utilice los tapa huecos para cubrir los tornillos aparentes.

